

Tech Partners Update

ITO - R.Ford
February 28, 2006

PORTAL UPDATE

- It is running but the public announcement of its availability has been delayed while we use it for critical internal testing
- Recall that it shares the same front end (presentation) architecture as Banner 7 -- all I/O via Web, created by and delivered through Oracle 10gAS
- Both Banner 7 and the portal involve a lot of “secure” pages, which in term involve SSL certificates and en/de-cryption
- The portal is currently being used to test performance issues related to SSL and the 10gAS architecture -- i.e., we can test this now with the portal to investigate some concerns that might impact Banner with it goes live -- hope to release to public soon

MIDDLEWARE/DIRECTORY UPDATE

- Things continue to NOT go well with the iPlanet/LDAP environment -- we have not been able to upgrade this software and the prospects that this will change in the future continue to be bleak.
- This continues to have serious impacts on directory integration, portal development, student email “uptake”, ... -- our time/patience is going, GOING, ...
- **GONE** -- we have decided that dramatic change in direction is necessary, effective immediately, to break out of what is otherwise bound to be disaster ...

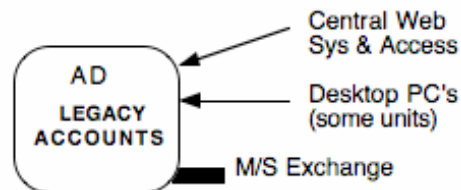
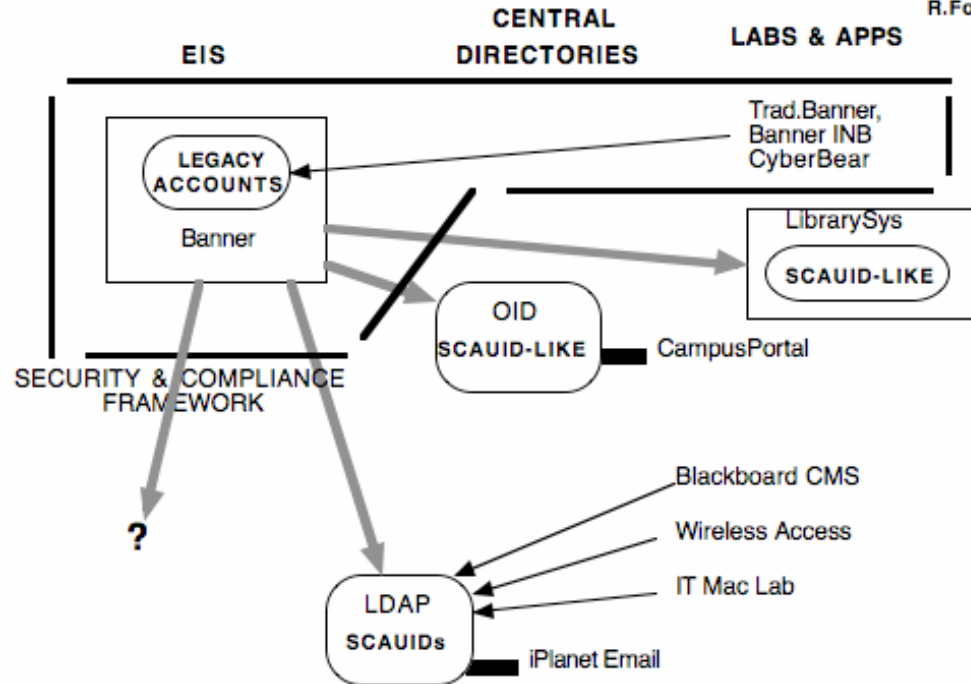

Using local servers or directories, or operating "stand alone"

- Some desktop PCs
- IT and non-IT PC labs
- non-IT Mac labs
- Unix/Linux Labs
- Non-IT Web sys & servers

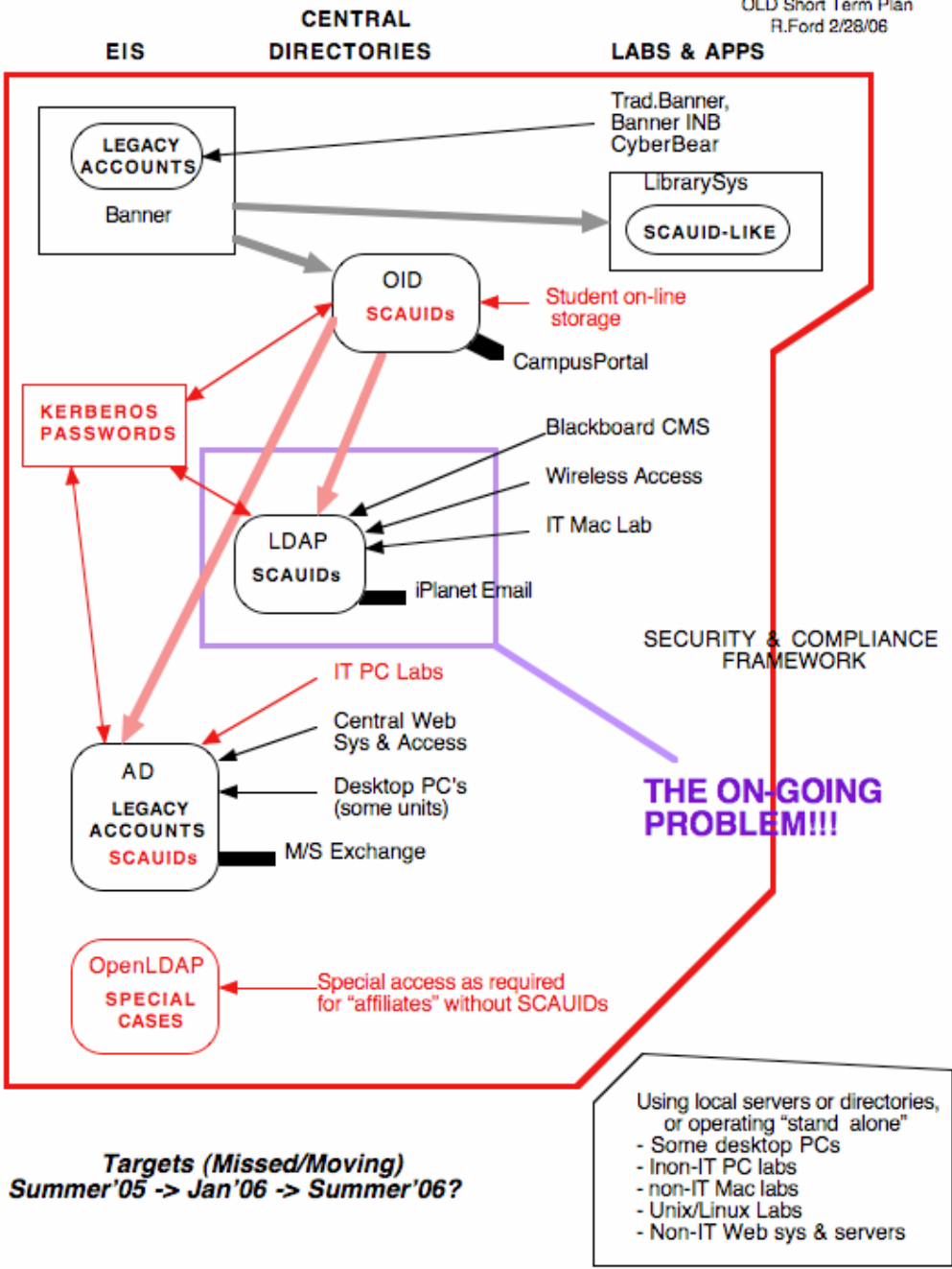

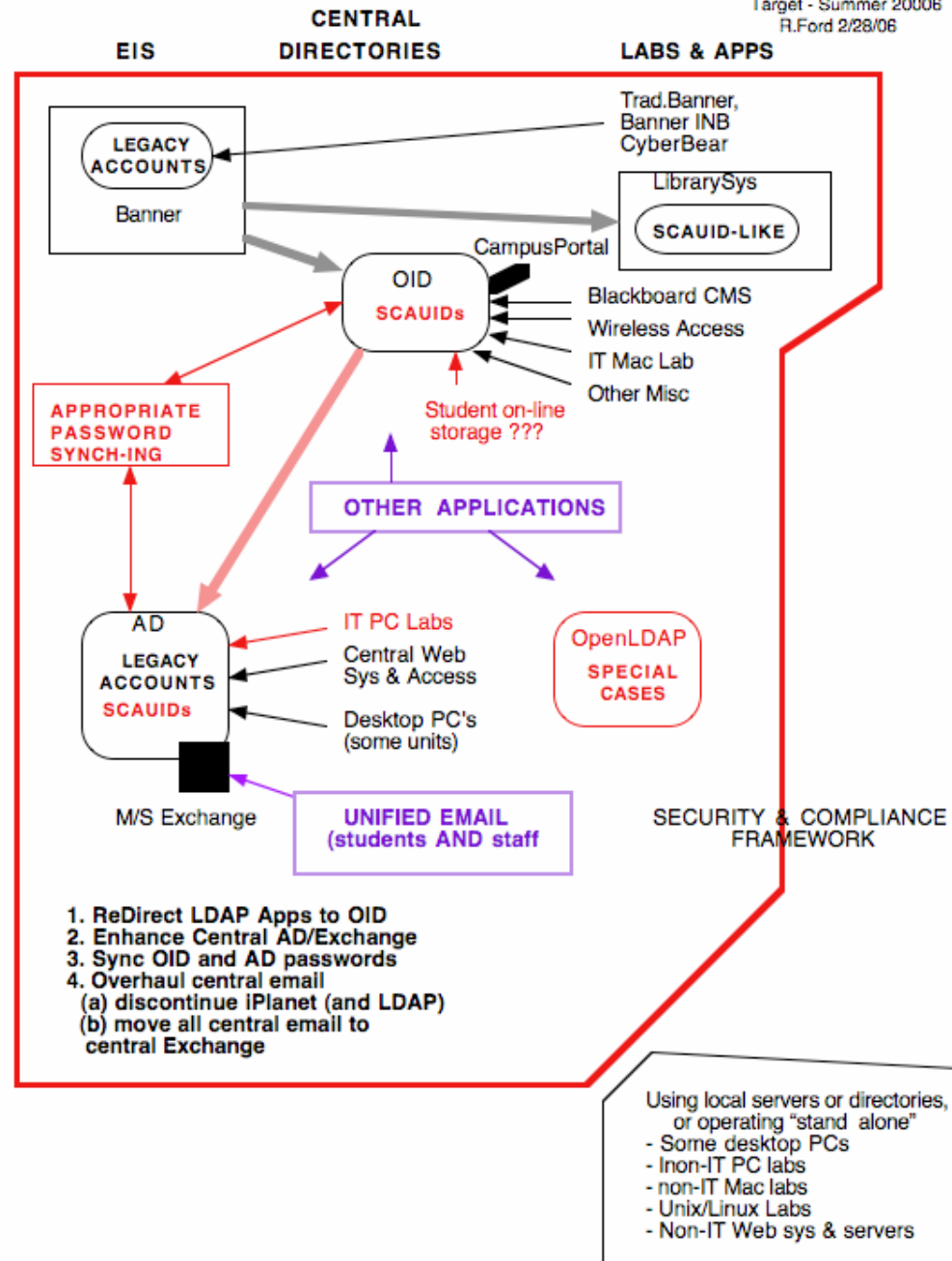

SUMMARY

UPSIDE - FOR SURE

Two directories vs. three and one email system vs. two ==> more effective use of staff time (sys admin ... support ... compliance)

UPSIDE - POSSIBLE

Perhaps more desirable email system will improve student uptake

DOWNSIDE - POSSIBLE

We'll enhance the hardware, but we may still get a less robust Exchange system (15,000 vs. 1500 users)

NEW ISSUES - FOR SURE

Questions about how/if to utilize Exchange's enhanced functionality for students (e.g., calendaring, address book, ...)